

## Channel waste LINEAR

Product Code: FD80L / FD90L / FD100L / FD120L

800/900/1000/1200 (l) x 70(w) x 21(d) mm  $\phi$  45mm

**Features:** Superior fall/centre outlet • 316 grade stainless steel • Manufactured from high-quality maintenance-free materials

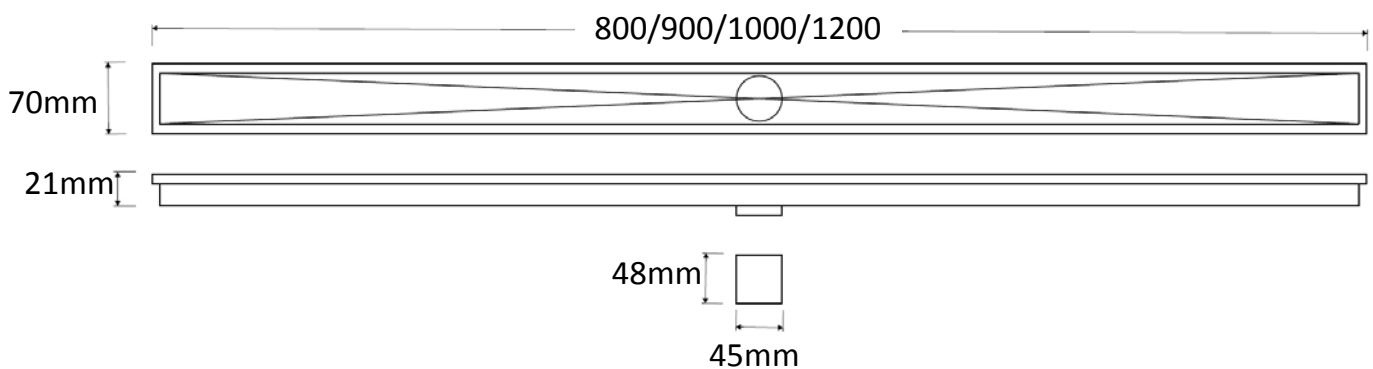
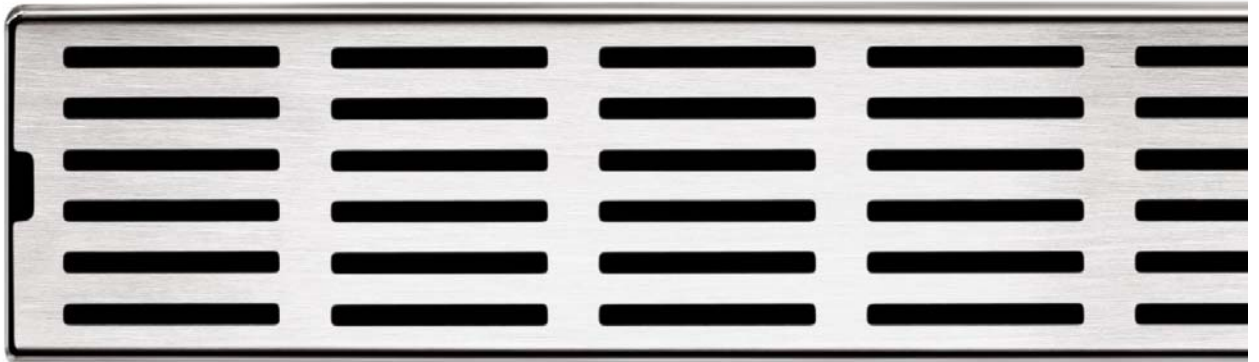

### Installation Diagram

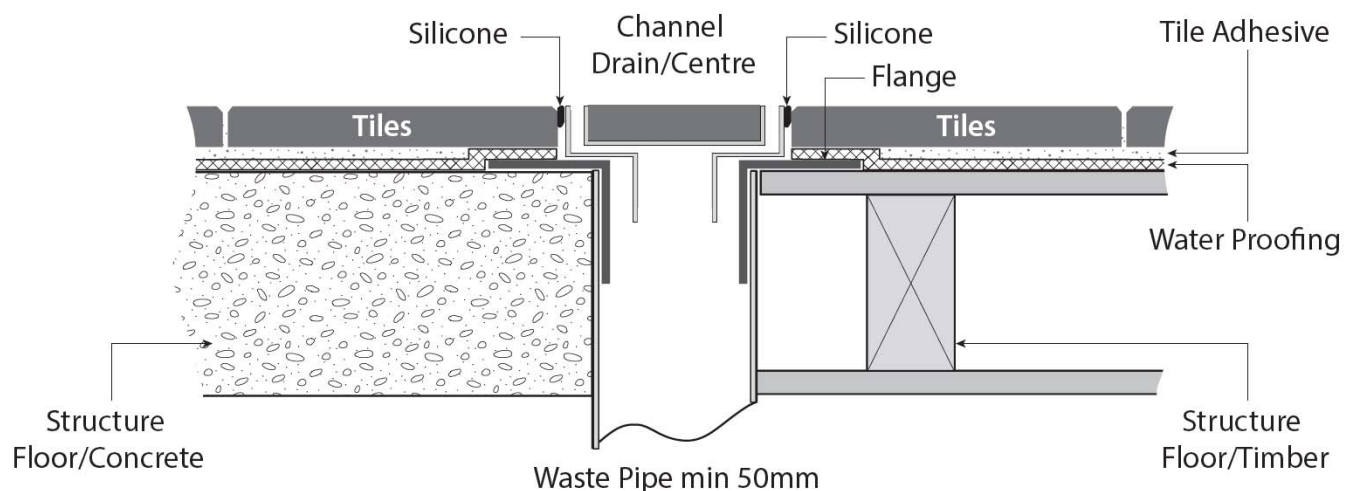

### Additional Information

- 5 year warranty